

TECHNICAL SHEET

1. DESCRIPTIVE

Mobile absorbent station for spills.

The recycling unit allows to separate the saturated absorbent from the absorbent that can be used again.



2. PRINCIPLE OF OPERATION



1. Stock & Distribute

The shovel to perfectly collect the absorbent and spread it over the area to be treated.

2. Absorb

Thanks to the provided brush, sweep the concerned area. Be generous and do not pay attention to the quantities as you can recycle the absorbent.

3. Collect & Recycle

Collect thanks to the shovel and then place it on top of the sieve. Shake the sieve over the mobile station so that the non-saturated product falls to bottom of the tank. The saturated absorbent staying at the top of the sieve under the form of lumps.



MAIN CHARACTERISTICS

- Absorbs 8 times more than traditional absorbents : clay / sawdust...
- instantaneous absorption
- Any kind of floor: epoxy, paint, concrete...
- Non abrasive
- Silica Free
- Fireproof & waterproof
- Biodegradable and incinerated

ADDITIONAL PRODUCT

- Absorbent Refills

3. TECHNICAL CHARACTERISTICS

Dimension of the Station	L 570 x l 689 x H 1090 (mm)
Empty weight	22,5 kg
Capacity	50L maximum (1 advised refill, maximum of 2)
Composition	PEHD
Included	Shovel, Broom, Clips, Sieve

TECHNICAL SHEET

4. DRAWING OF THE STATION

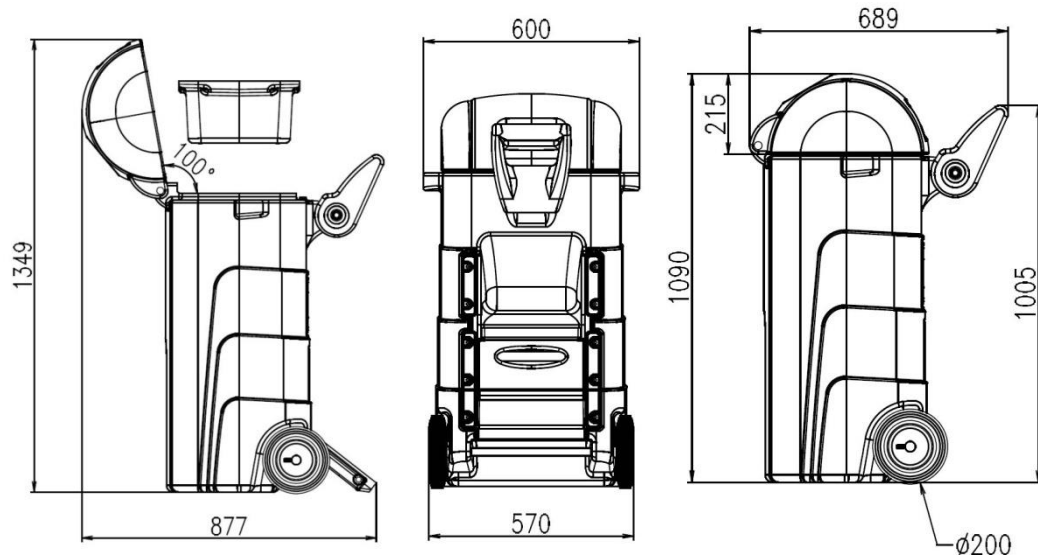

5. 3D VIEWS

